

This document is exclusive MARECO LUCE s.r.l., is strictly prohibited disclosure or reproduction, even partial, as well the use of without written consent of MARECO LUCE s.r.l..The company reserves the right to change models, dimensions and materials at any time without notice.

## PRODUCT DATA SHEET

### Mirò Coated

**Code : 1620152N**

#### PRODUCT FAMILY

Urban architectural with cut-off optics for use with Ø60mm brackets (IP65)

#### MATERIAL CHARACTERISTICS

Hexagonally shaped base in die-cast aluminium EN AB 46100 highly castable and flowable to prevent formation of air bubbles and allow the filling of castings with thin walls, treated by cleaning, degreasing and brushing.

Then phosphating with zinc salts followed by passivation with demineralized water and oven drying at 110°C

Thermosetting powder coating (based on carboxylated saturated polyester resins specifically selected for their high resistance to weathering) (hardener without TGIC) having pigments with high stability to light and heat

Thermo-polymerization at 200°C

Body in thick (3.5mm) transparent PMMA, hexagonally shaped at base (connection to aluminium base) and circular (connection to diffuser):Pre painting process:

with texturised bi-component polyurethane enamel (hydroxylated resin-based, and modified for high elasticity and adhesion), formulated in order to achieve maximum strength.

Painting process:

with bi-component polyurethane enamel (hydroxylated resin-based, and modified for high elasticity and adhesion), formulated in order to achieve maximum strength and exceptional exterior hardness.

Diffuser in transparent PMMA

Cone covering gear tray in black, moulded NYLON-FIBREGLASS30% bi-component semi-gloss white Acrylic enamel (acrylic-isocyanate resin-based), highly resistant paint.

Colours: Black

Gaskets in silicone

Screws in stainless steel A2

#### LIGHTING CHARACTERISTICS

Fixture conforms with local and international dark sky laws

Lamp is in a fixed position

#### WIRING CHARACTERISTICS

Easily extractable gear tray made from NYLON-FIBREGLASS30% connected to terminal with automatic connection

Ferromagnetic ballast

#### INSTALLATION AND ORDINARY MAINTENANCE CHARACTERISTICS

Fixture for Ø60mm bracket installation

Fixing to pole using n.3 screws, n.1 of which is a through bolt (safety)

Tool-free ordinary maintenance through small handles placed at the bottom of the diffuser in order to access the optical compartment

#### MEASUREMENT CHARACTERISTICS

Conically shaped fixture with hexagonal-circular sections having a maximum diameter of Ø470mm and height of 420mm, with flat-circular cover

#### Details

- Conformity with CEE directives
- Double insulation/class II
- Mounting on normal flammable surface
- Against lighting pollution
- Resistant to atmospheric agents
- Inalterable to ultraviolet radiations
- Conforms to all regional/local laws against light pollution
- IP 65

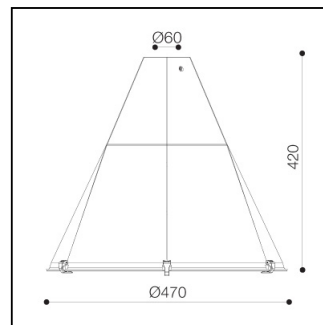

230V 50Hz 70W E27

