

GENERAL MAINTENANCE RECOMMENDATIONS:

- THE BASE AND THE OTHER PARTS OF THE PRODUCT CANNOT BE COVERED BY SOIL OR PUT IN CONTACT WITH AGGRESSIVE CHEMICAL SUBSTANCES (HERBICIDES, FERTILIZINGS, ETC).
- CLEAN THE FITTING PERIODICALLY TO REMOVE POSSIBLE DIRT/GROUND DEPOSITS
- DO NOT USE HARSH DETERGENTS TO CLEAN THE DIFFUSER
- CHECK THE TIGHTNESS OF THE SCREW SECURING THE FITTING.
- CHECK THE INTEGRITY OF THE FITTING COMPONTS: REPLACE THEM IN CASE OF DAMAGE BY USING ONLY ORIGINAL MARECO LUCE PARTS
- CHECK THE PLASTIC CASINGS CAREFULLY IN ORDER TO IDENTIFY ANY POSSIBLE INSULATION DAMAGE
- IT IS RECOMMENDED TO USE SILICONE GREASE ON THE THREADED PARTS OF THE CLOSING SCREWS IN ORDER TO MAKE FUTURE MAINTENANCE

Use and maintenance instructions

Lux Est 1058/1059

Fixed bollard for outdoor use, to be installed on concrete plinth

TECHNICAL DETAILS: refer to the product label

 The UE declaration of conformity can be downloaded from our website www.marecoluce.it

 Insulation Class II

IP65 Protection degree against dust ingress, solid particles, moisture

 This product must not be disposed as a normal household waste

WARNINGS.

- THE SAFETY OF THIS PRODUCT IS GUARANTEED ONLY WITH THE RESPECT OF THE EXISTING RULES FOR THE ELECTRICAL SYSTEMS, AND WITH THE APPROPRIATE USE OF THESE INSTALLATION INSTRUCTIONS, THEREFORE IT IS NECESSARY TO KEEP THEM.
- THE IMPROPER USE OF THIS PRODUCT IS FORBIDDEN; ANY TAMPERING WITH THE PRODUCT OR MODIFICATION OF THE PRODUCT THAT IS NOT AUTHORIZED BY MARECO LUCE CAN CAUSE DAMAGE TO PEOPLE, ANIMALS OR THINGS, AND WILL VOID ANY WARRANTY OR LIABILITY.
- SWITCH OFF THE ELECTRICITY BEFORE CONDUCTING ANY KIND OF MAINTENANCE.
- THE PRODUCT MUST BE INSTALLED IN ACCORDANCE WITH BEST PRACTICE.
- DAMAGED COMPONENTS MUST BE REPLACED BEFORE PUTTING THE PRODUCT BACK INTO SERVICE WITH MARECOLUCE SPARE PARTS.
- THIS PRODUCT IS SUITABLE FOR OUTDOOR INSTALLATION ONLY.
- DO NOT REST OBJECTS ON THE DIFFUSER, DO NOT COVER OR OBSCURE IN ANY WAY
- FITTING SUITABLE FOR LAMPS OF THE FOLLOWING MAX. SIZE (IN MM)

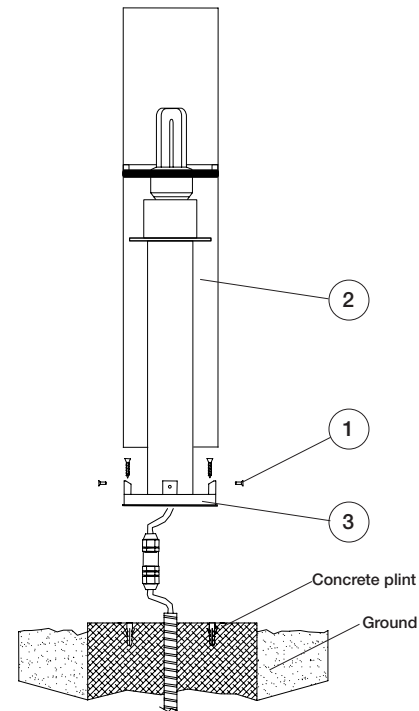
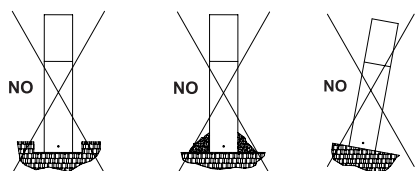
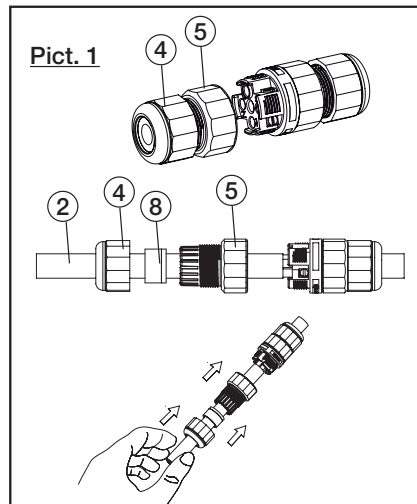

- o 27W D61 L210
- o 25W D61 L164
- o 21W D61 L155
- o 16W D61 L136

A85
B425/680/1000
C85
D85
Fixing holes
Ø6mm 62X62mm

A85
B510/765/1085
C85
D85
Fixing holes
Ø6mm 62X62mm

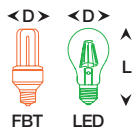
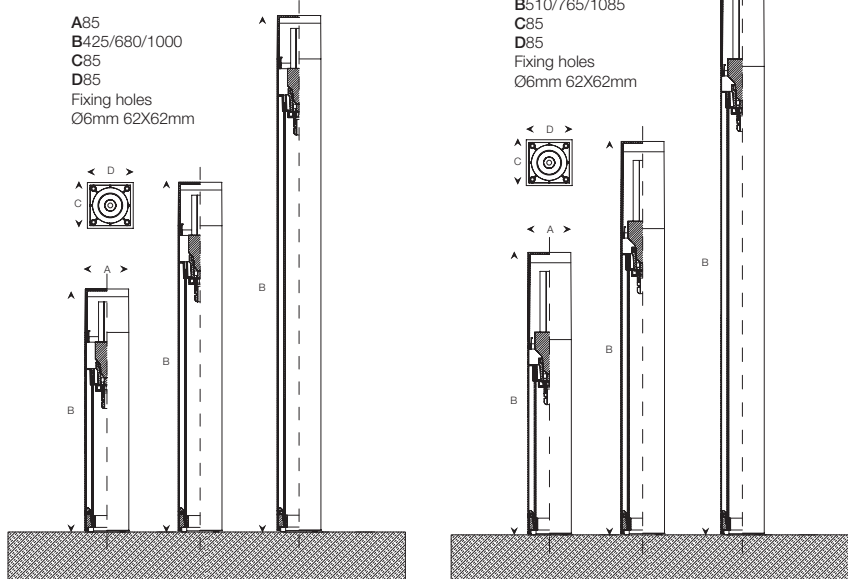

Pict. 2

Guide for the correct cable polarity

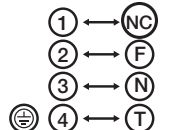

If necessary, control the earth connection indications on the product label

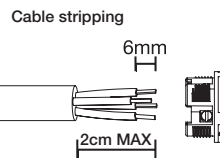

INSTALLATION INSTRUCTIONS:

1. Untighten the screws (1) and remove the square cover (aluminium body + diffuser) (2).
2. Untighten the ferrule (5) of the tinned terminal block (see Pict 1 and 2).
3. Insert the supply cable (2) in the ferrule (5).
If needed, untighten the ferrule (4) and insert the supply cable also into the gasket (8) and then within the ferrule (5). (see Pict.1).
Connect the supply cable by respecting the polarities and the cable sheathing (see Pict.2)
4. Close the terminal block by tightening the ferrule first (5) and then close the other ferrule (4) to make a watertight connection and ensure the declare IP rate.
- CAUTION:** use only a flexible double insulation sheath (type HAR) or one suitable for outdoor use. The outer cable diameter must range between 7 and 12 mm. If a cable with diameter higher than 9mm is used, remove the inner gasket (8). The thickness of the inner electrical wires must range between 0,5 and 1,5 mmq.
5. Fix the base (3) to the mounting surface through screws and expansion caps (not included in the packaging).
6. Insert the lamp (not included)
7. Insert the square cover (aluminium body +diffuser) (2) into the base (3) and tighten the screws (1).